

Custom Chain Guides, Belt Guides, and Profiles

Custom Chain Guides

Slideways manufactures chain guides for all roller chains including metric and multi-strand.

Materials of choice include:

- Oil-filled UHMW for high-speed applications
- Nyloil for heavy-duty applications
- Glass-filled Teflon for high temp or chemical resistance
- MD-Nylon for high load capacity
- Static-dissipative UHMW for electronics applications

There are many advantages to using custom-machined guides over extruded guides:



Machined Profiles

- Usually no tooling
- Short lead time
 - 2 weeks or less
- Tight Tolerances
 - Machine to $\pm .005"$
- Design flexibility
 - Designs can change quickly
 - Try new material
- No minimum runs

versus

Extrusion

- Tooling required
- Long lead time
 - 5-8 weeks for tooling
- Loose tolerances
 - Cooling rates cause warping
- No design flexibility
 - New tool required for revisions
 - Minimum run required
- Large minimum run

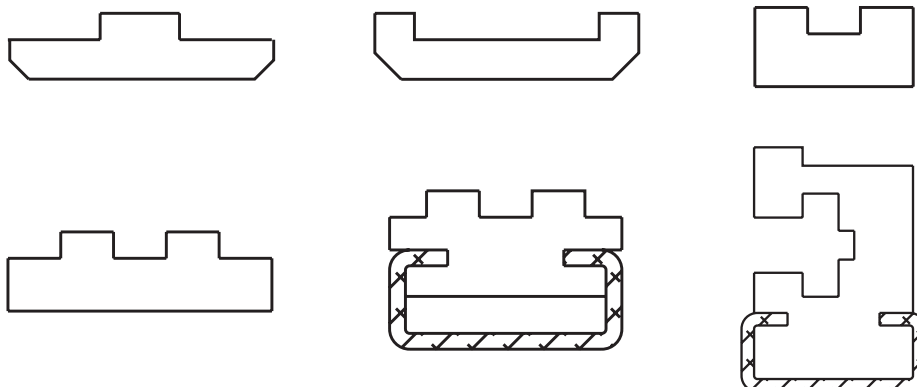
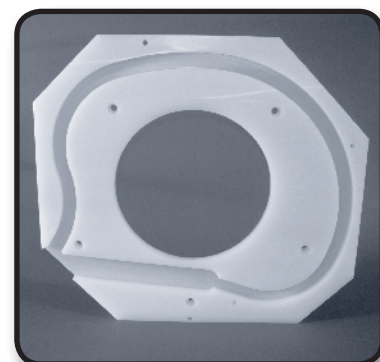

ROLLER CHAIN GUIDES FOR: #25, #35, #40, #40-2, #50, #50-2, #60, #60-2, #80, #80-2, #100, #120 AND METRIC SIZES